

# ***TDI TURBOTWIN T30-P***

## ***TURBOTWIN T30 SERIES*** The Benefits Are Yours

- The gear train and bearings are factory grease-packed for the life of the starter, so it requires no maintenance. There are no rubbing parts, so there is no external lubrication required. Lubricator problems, installation expense, system maintenance, and the messy and hazardous oil film around the starter exhaust . . . all are eliminated
- The TURBOTWIN T30-P starter fits a wide range of engine applications, up to 20 liters. One basic design can be used for a broad range of engine types.
- The TURBOTWIN T30-P is ideal for remote or "black" start applications. The unit requires only simple control lines for its operation.
- Piping consists of only a single supply line with a ball valve or TDI relay valve in the line. See the typical manual or electric installation diagrams.
- The efficient twin-turbine motor design increases the torque applied to the ring gear, using less air per start than competitive designs. Refer to the performance curves for 6 nozzle models. The T30 Series includes models with 3, 6, and 12 nozzles.
- The T30-P starter can be used over a wide range of drive pressures from 30 psig (2 BAR) to 150 psig (10 BAR). It is suitable for operation on either compressed air or natural gas. The lightweight, 29 Lb, unit is capable of delivering over 21 HP (15.65 kW) of cranking power at only 120 psig (8 BAR).
- TURBOTWIN T30 Series starters are constructed from durable, high quality materials. Major components are made from high strength aluminum or steel alloy.
- The durable turbine motor design in the TURBOTWIN T30 Series has no rubbing parts. It's tolerant of solid and liquid contamination in the supply gas with nearly no adverse affects. The motor is well adapted to running on "sour" natural gas.

**ENVIRONMENTALLY  
SAFE**

**APPLICATION  
VERSATILITY**

**SIMPLICITY**

**EASE of  
INSTALLATION**

**LOWER AIR  
CONSUMPTION**

**BROAD RANGE  
OF OPERATION**

**HEAVY DUTY  
CONSTRUCTION**

**CONTAMINATED  
SUPPLY GAS**

- TECH DEVELOPMENT INC. introduced the first turbine technology for starting industrial engines in 1979. The TURBOTWIN T30 Series features an innovative and more reliable turbine motor than anything on the market today.

## DEVELOPMENT HISTORY

The TURBOTWIN T30 Series is the result of TDI's continuing turbine starter design innovations. Based on our successful TURBOTWIN T100 Series starters, the TURBOTWIN T30 Series starters should exceed customer requirements in every installation.

- The high horsepower of a turbine air motor combined with the planetary gear speed reducer results in a very efficient and compact unit. The TURBOTWIN T30 Series models are powered by a pair of axial flow turbines coupled to a simple planetary gear reduction set.

## DESCRIPTION of OPERATION

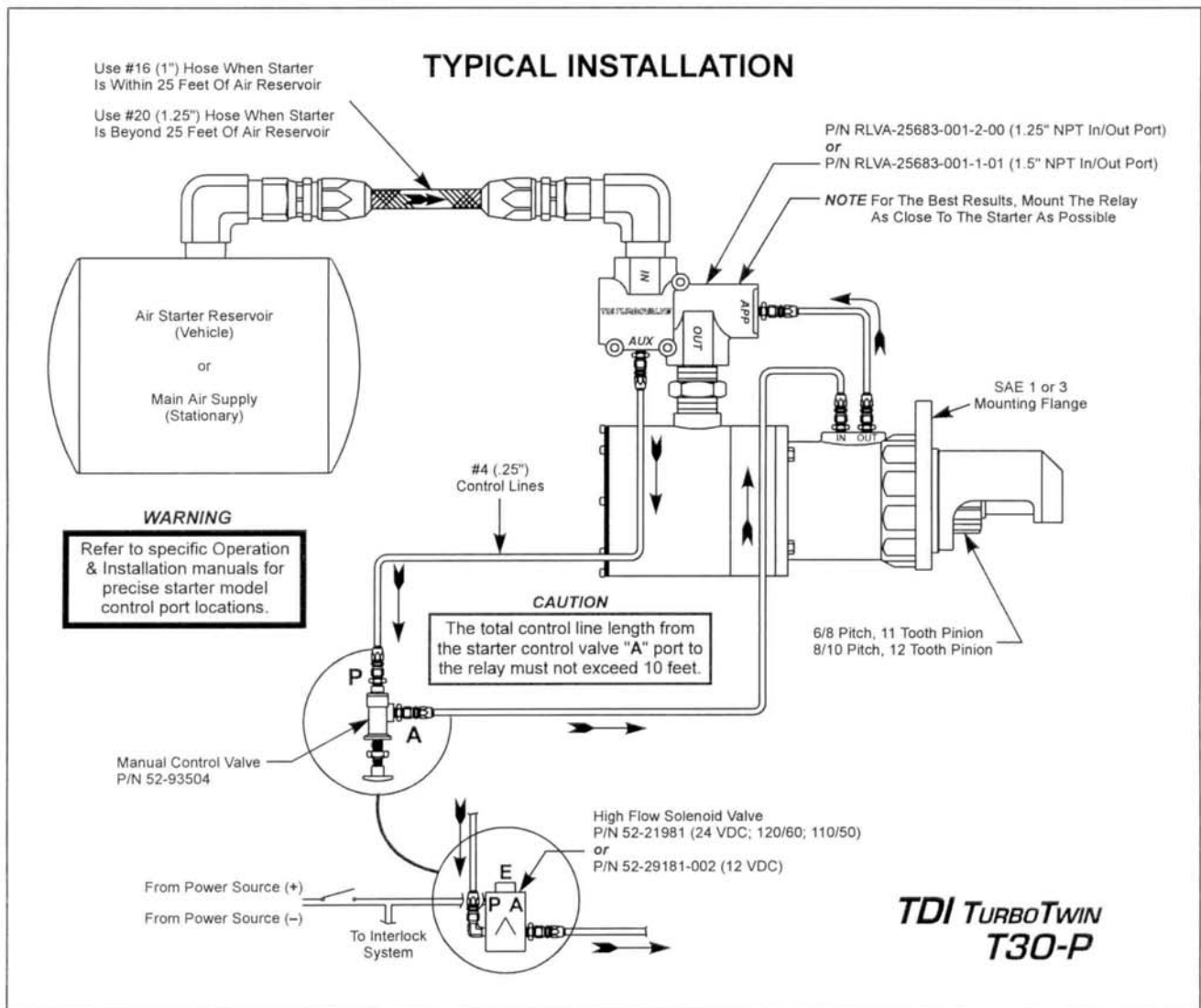

# DIMENSIONAL DATA

**TDI TURBOTWIN  
T30-P**

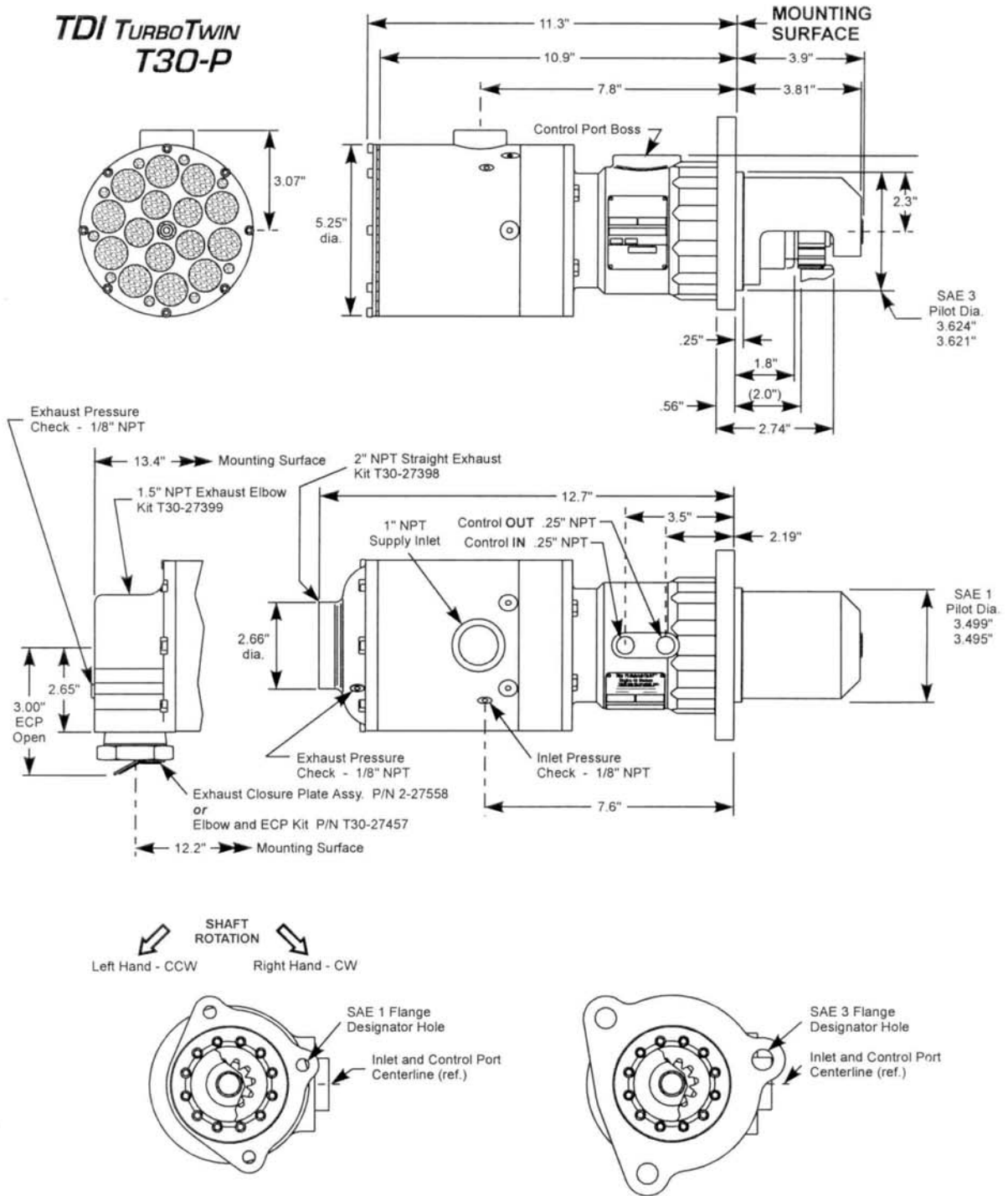

# TDI TURBOTWIN T30-P PERFORMANCE CURVES

**Model T306-P**  
**6 NOZZLES**  
70° F, Compressed Air  
9.0:1 Ratio

INLET Pressure	FLOW (Scfm)
150 PSIG	600
120 PSIG	478
90 PSIG	365
60 PSIG	255

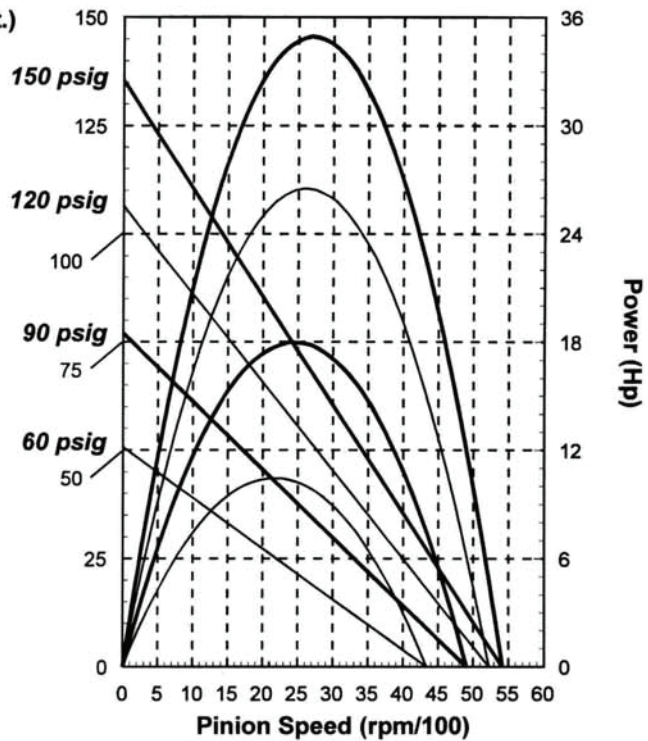

**Model T306-P**  
**6 NOZZLES**  
70° F, Methane Gas  
9.0:1 Ratio

INLET Pressure	FLOW (Scfm)
120 PSIG	600
90 PSIG	465
60 PSIG	330

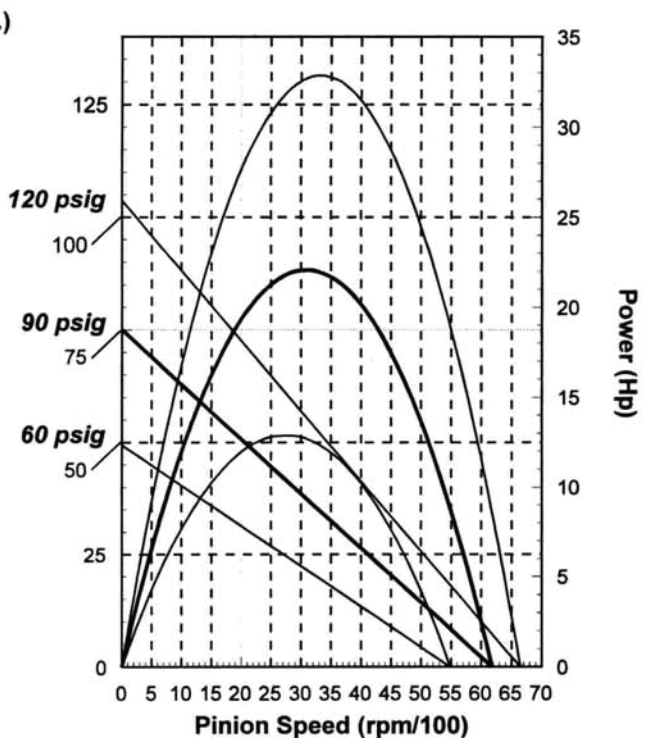

T30 Series: Flexibility To Meet Any Requirement

T30-I Inertia Engagement    T30-P Pre-Engaged    T30-Y Pre-Engaged/Overhung    T30-M Industrial Air/Gas Drive Motor

**RJ Mann & Associates Inc.**  
*Engine Controls & Panels/Compressor Parts*

860 North 9th Avenue, Brighton, CO 80603  
Ph: (303) 659-5139    Fax: (303) 659-5309  
www.rjmann.com

Pub T30-713 6/97    Man AN96-613